

Automatic Wood Processor with Conveyor

OWNER 'S MANUAL



WARNING: Read carefully and understand all **INSTRUCTIONS** before operating. Failure to follow the safety rules and other basic safety precautions may result in serious personal injury.

FIREWOOD PROCESSOR

1 Machine Description	5
2 Safety regulations	6
3 Specifications of machines	8
4 Transportation of machines	10
5 Installation of machines	13
6 Operation	23
7 Maintenance	23
8 Wear parts	24
9 Hydraulic drawings and components list.....	25
10 Attaching information.....	25
11 Note	26

1 Machine Description



A very efficient and user friendly log splitter that cuts and splits the log in one operation. Splits logs up to 530/550mm long and 300/380mm in diameter. Pull the handle of the chain saw lightly and push the log holding handle, the chain saw starts to cut the log. After finishing cutting, release the handles, then the handle is automatically reset. The chain saw stops working, and the splitter starts automatically. This ensures high safety, lower noise and longer life of both chain and bar.

2 Safety regulations

The machine may only be used in the manner prescribed in this manual. Deviations may lead to that the health and safety requirements are not met. The user is responsible to read through the instructions and follow them properly.



WARNING!
Never tamper with the machine's functionality or construction. It may lead to a deterioration of safety!



WARNING!
Never leave the machine unattended during operation!

Symbol explanation



Wear safety goggles



Wear protective clothing



Wear safety shoes



Wear safety helmet



Wear hearing protectors



Wear safety gloves

Attention!

- a) "Danger! Keep clear of moving parts!"
- b) "Wear eye protection!"
- c) "Wear protective gloves!"
- d) "Wear safety footwear!"
- e) "Wear hearing protection!"

Operation safety

The machine shall only be used by one person at a time. No other than the user may stay in the risk area around the machine. The risk area covers 230mm around the machine.



Personal safety

Protective equipment must be used while operating the machine.

Machine safety

The machine is intended for use in outdoor environment and for log cutting and splitting only. To obtain best functionality, do not split the logs into pieces shorter than 300mm.



WARNING!

Check before each use that the auto splitter stops when the protective cage is opened! If this feature does not work, the machine must not be used!



WARNING!

Never use a defective machine!
Be careful when cutting and splitting the log!

3 Specifications of machines

3.1 Exploded views and spare parts

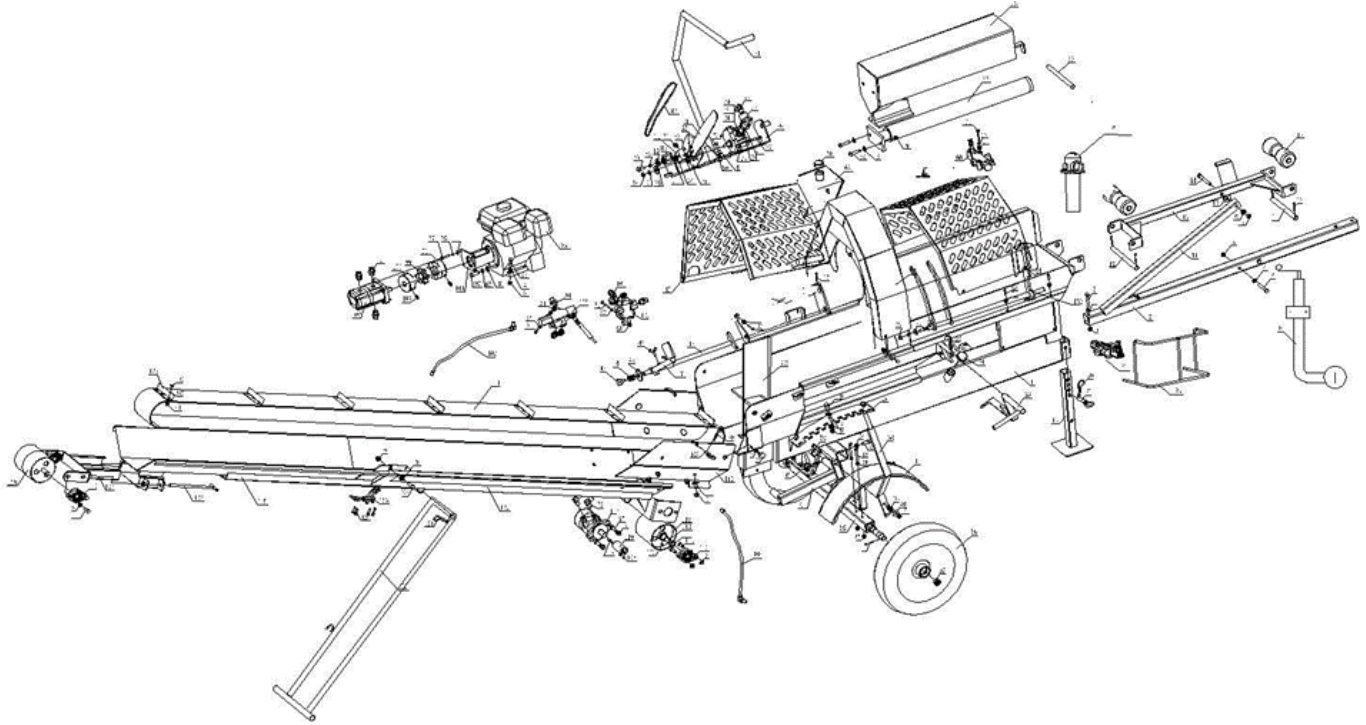

No.	N a m e	Qty	No.	N a m e	Qty	No.	N a m e	Qty	No.	N a m e	Qty	No.	N a m e	Qty
1	Main body	1	33	M8 JCT0 bolt	4	85			97	M12X35 bolt	6	129	Conveyor connecting board	13
2	Draw bar	1	34	Flat washer Φ 8	20	86	Log pusher welding part	1	98	Coupling (1)	1	130	Snap-head bolt M6X16	39
3	M10X70 bolt	3	35	Axle welding part	1	67	Oil cylinder	1	99	Coupling cushion	1	131	Conveyor belt (length 5600)	1
4	Flat washer Φ 10	9	36	Rubber wheel	2	68	M12X40 Semicircular head hexagon socket	2	100	Coupling (2)	1	132	Log pressing handle	1
5	Self-lock nut M10	16	37	Axle nuts	2	69	lubricating oil tank welding part	1	101	2-G1/2 connector	8			
6	Manual guide wheel	1	38	M10X65 bolt	1	70	Oil filler cap	1	102	Oil pump	1			
7	M12X70 bolt	2	39	Spring (inner diameter Φ 1 5)	1	71	Chain saw handle welding part	1	103	M6x10 set screw	5			
8	Flat washer Φ 1 2	17	40	Φ 1 0 spacer	1	72	Hydraulic pipe (2)	4	104	Oil pump fixing base	1			
9	Self-lock nut M12	21	41	Knife connecting tube welding part	1	73	Oil pump outer connector	2	105	CEBA valve	1			
10	European style cover	1	42	Φ 5 S p r i n g c o t t e r	1	74	M6X55 hexagon screw	6	106	CGDG2 valve	1			
11	Roller support tube	1	43	Hopper connection plug	3	75	Φ 8 Spring washer	16	107	High-pressure oil pipe	7			
12	Roller shaft (1)	1	44	S p r i n g (l i n e r diameter)	1	76	Motor base welding part	1	108	Low pressure oil pipe	4			
13	Roller frame welding part	1	45	Big flat washer Φ 2 0	1	77	M6X35 hexagon screw	8	109	Conveyor fixed pin welding part	2			
14	M12X100 bolt	1	46	M6X15 Butterfly bolt	2	78	Chain Saw Oil Pump	1	110	Conveyor connecting board	left & right			
15	Big flat washer Φ 1 2	2	47	Welded base	1	79	M10X20 bolt	2	111	carriage bolt M12X25 (short)	9			
16	roller shaft (2)	1	48	Welded base	1	80	Φ 1 0 spring washer	2	112	Roller B welding part	1			
17	Φ 3X35 cotter pin	7	49	Left guard welding part	1	81	Chain saw bar	1	113	Roller B support shaft	1			
18	roller	2	50	M6X40 bolt	3	82	Saw chain	1	114	Φ 2 5 shaft ring	1			
19	Outrigger welding part	1	51	M6self-lock nut	57	83	Adjusting rivet	1	115	M10X30 bolt	6			
20	Φ 3 Spring cotter	4	52	Knife welding part	1	84	base	1	116	Bearing seat FL204	3			
21	Outrigger pin welding part	1	53	Chain saw guard welding part	1	85	M6X55 bolt	2	117	motor	1			
22			54	Right guard welding part	1	86	Φ 1 2 spring washer	6	118	Flat key 8X40	2			
23	Lever welding part	1	55	Feed protection plate (2)	1	87	M12X25 bolt	1	119	Connection set	1			
24	dipstick	1	56	Feed protection plate(1) welding part	1	88	Chain wheel cushion	1	120	hopper(1)welding part	1			
25	M6X25 bolt	3	57	M6X60 hexagon screw	5	89	Chain wheel	1	121	Φ 4 spring cotter	1			
26	Φ 3 big flat washer	3	58	M6X20 bolt	4	90	Tee joint	1	122	hopper outrigger welding part	1			
27	M8 self-lock nut	7	59	Right guard protection plate	1	91	G3/4-G1/2 connector	2	123	4003 clamp	1			
28	knife limiting board	1	60	CHDG valve	2	92	M6X25 hexagon screw	2	124	M6*16 Cross recessed countersunk head bolt	5			
29	M12X30 bolt	7	61	M6X60 bolt	6	93	Φ 6 spring washer	2	125	hopper (2) welding part	1			
30	Knife handle welding part	1	62	Φ 6 flat washer	47	94	Oil filter	1	126	Adjustment rod welding part	2			
31	Fender welding part	2	63	M24 Nut	1	95	Gasoline engine	1	127	Adjust seat welding part	1			
32	M12 nut	3	64	guard	1	96	M10X35 bolt	4	128	Roller A welding part	1			

3.2 Identification Data

Every machine we produce is fitted with a name plate with its serial number. The number is also punched on the machine.

An exact description of the machine model and serial number will facilitate rapid and effective replies from our after-sales service.

All the models are identical machine except the model name, the following name plate is one example:

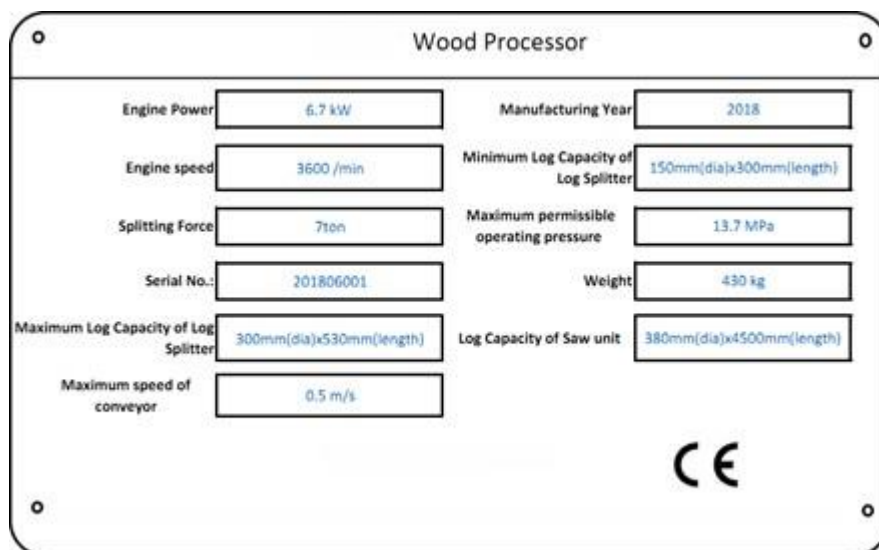

4 Transportation of machines

4.1 Transportation and store

The measures of anti-rust and shockproof should be taken during packing. The machine endures transportation and store in $-25\sim 55^{\circ}\text{C}$ ambient temperature.

Be care of not making machine exposed to rain or damaging the packing during transportation and store.



- While transporting or handling the machine, be careful and let the activity be done by qualified personnel especially trained for this kind of activity!

- While the machine is being loaded or unloaded, make sure that no person or subject gets pressed by the machine!



- Select proper transportation device according to the weight of the machine. The weight of the machine you select please refer to Chapter 3.

Make sure the lifting capacity of transportation device is competent for the weight of the machine.

4.2 Transportation before unpacking

As standard, the machine is packed in a robust wooden box. The following figure shows the method can be used to transport the packing box.



Fig. 4-1 transportation sketch (Before unpacking)

4.3 Confirmation after unpacking

When open the packing box, please pay attention to the following stems.

If you have any questions, please contact directly with us.

- 1) the machine is damaged in transportation or not
- 2) other accessories and documents is complete or not
- 3) the product is consistent with the contract or not
- 4) the specifications on machine label is consistent with the contract or not

4.4 With a crane



- The machine or its individual parts may only be lifted by means of an approved lifting device with verified lifting capacity.
- Make sure that no person or subject gets pressed by the machine!
- Use lifting belt with capacity to bear more than the machine weight (430kg).



Fig. 4-3 transportation sketch with a crane (after unpacking)



- If it is necessary to transport the machine after using, please protect pipes and cables firstly, then discharge the coolant fluid and impurity.

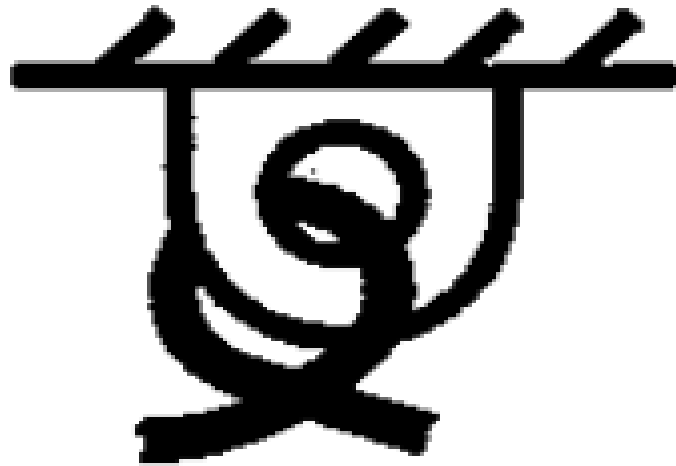

When transporting this machine from a long distance, it cannot be pulled on the road. It needs to be placed on the truck and transported after being tied in the place marked with binding points.

5 Installation of machines

5.1 Remove processor and all parts from the steel shipping crate.



5.2 Start by mounting the wheel axle To do this, the rear part of the machine should be lifted so that the wheels can be mounted. Insert axle through the processor ensuring it is centered and tighten the bolts to hold it securely in place.

Note: It is very important to ensure that the mounting holes face up, as they are used to secure the wheel mudguard in place.



5.3 Place a liberal amount of grease on the inside of the wheel hubs and in the bearings. Insert greased bearing, washer and nut over axle spindle and tighten the nut. The cotter pin can be inserted into the hole in the end of the axle. Finally, the dust cap can be installed. See below images.



5.4. Install the bracket to support the machine balance, then install the trailer pull rod and support wheels. The installation sequence is as follows 1,2,3.



5.5. Attach the conveyor belt, this is easiest done vertically and then fold down horizontally

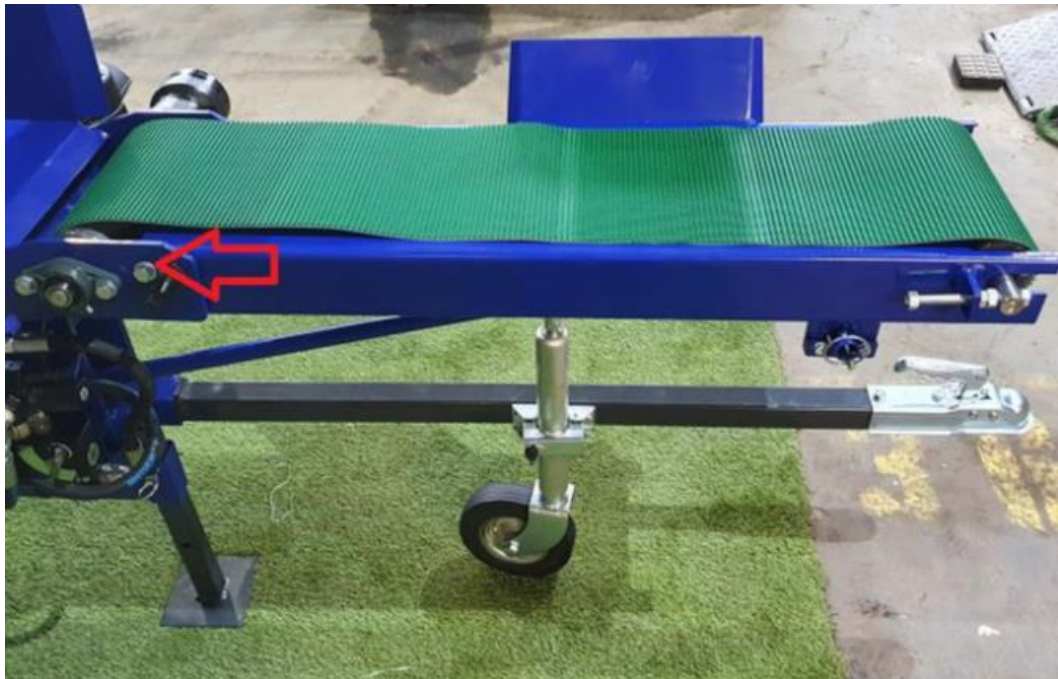

5.6. Install the fenders and attach to the axle using the two bolts as shown below.

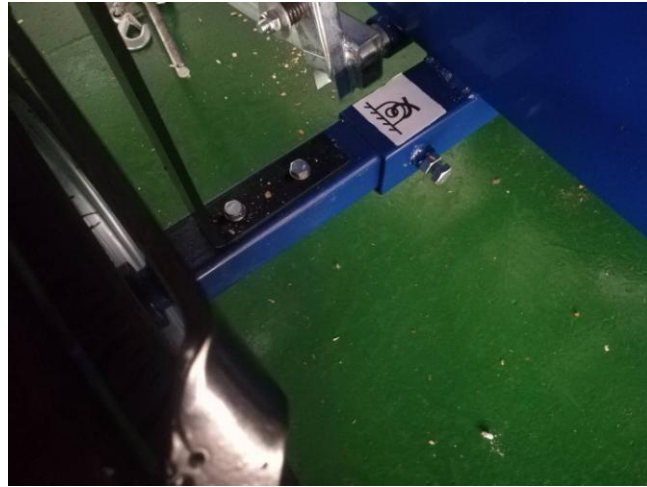

5.7. Match hydraulic line “A” up with fitting “A” on the control valve and tighten with a wrench.



5.8. Match hydraulic line “B” up with fitting “B” on the control valve and tighten with a wrench.



5.9. Install the hydraulic line to the chainsaw bar as per the images below and tighten with wrench.

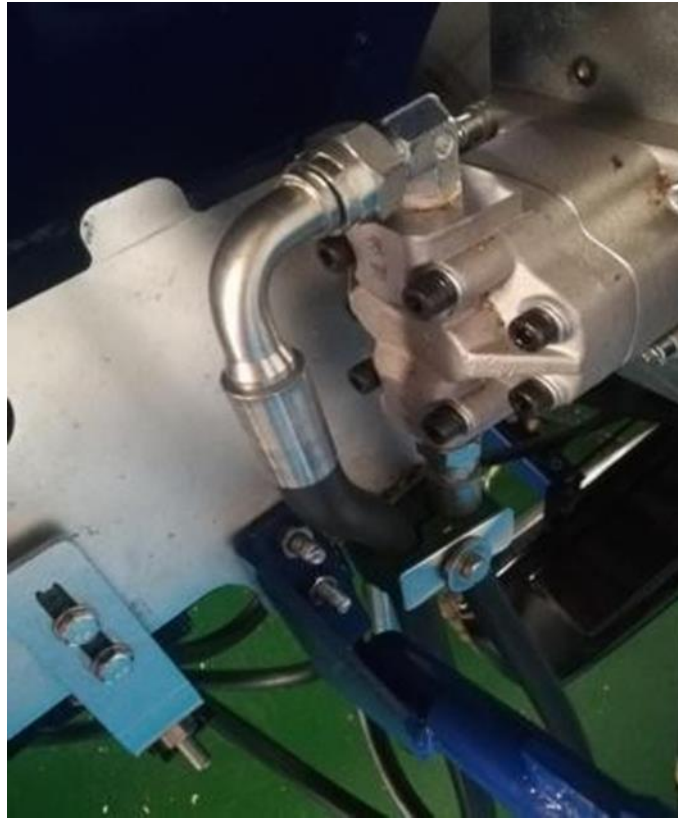

5.10. Install the chainsaw bar guard and tighten the 3 bolts in the areas shown below.



5.11. Install the backplate, reinforcement bracket, and top pulley housing onto the chainsaw bar guard using the provided bolts, and tighten all bolts

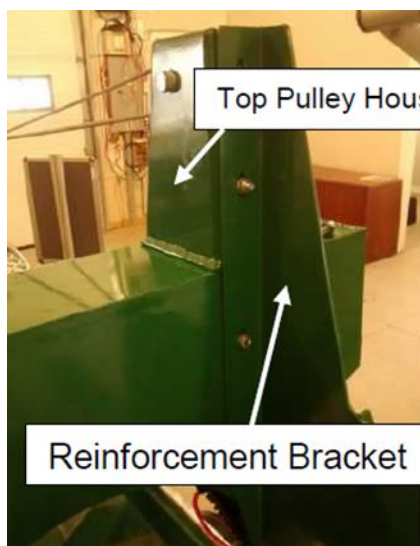

5.12. Remove the adhesive backing from the chainsaw bar guard and position the bar oil tank in place. Tighten nut to securely hold it in place. Attach the oil line to the spout on the chainsaw bar as shown in below right image.

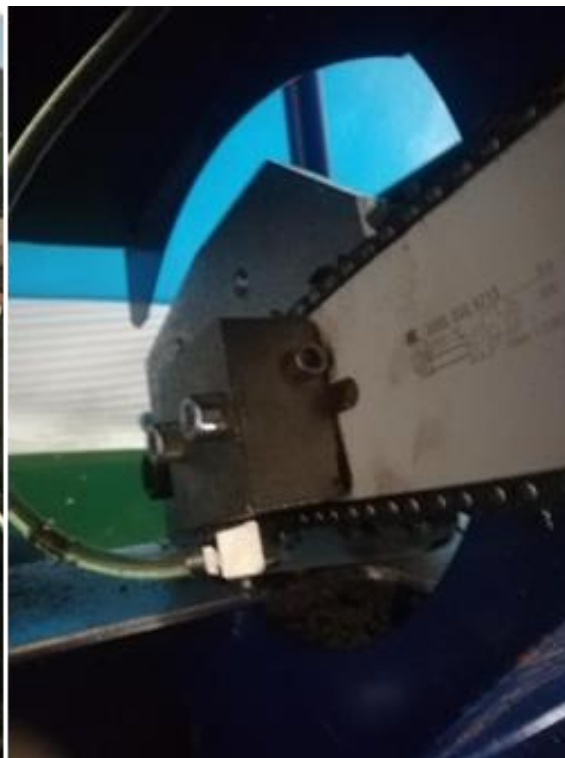

5.13. Install the chainsaw bar pull handle using the three bolts shown below. Also ensure the cable shown in the image on the right is in the lower hole.



5.14. Fix the buffer spring. This spring is used to aid in returning the chainsaw bar handle.



5.15. Install the large cage guard and wedge plate as shown below so that when the large cage guard is opened, the plate will depress the valve plunger. A smooth transition motion is recommended. There are slots in both directions allowing positional adjust ability to achieve proper actuation of valve.



5.16. Install the cage guard in place and tighten the three bolts as shown below.

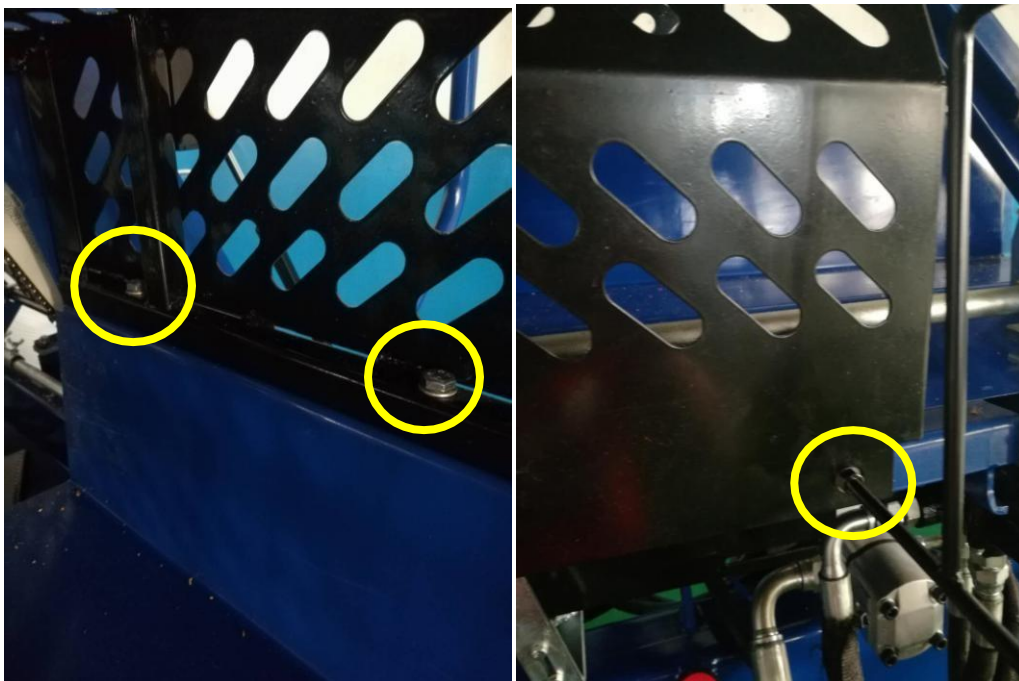

5.17. Install the notched plate on the processor with the two nuts and bolts provided. This plate is used to lock the handle in place which holds the 2/4 way splitter at the desired height. Turn the handle to left side with symbol arrow downward, the wedge height will move lower, turn the handle to right side with arrow upward, the wedge height will move upper.

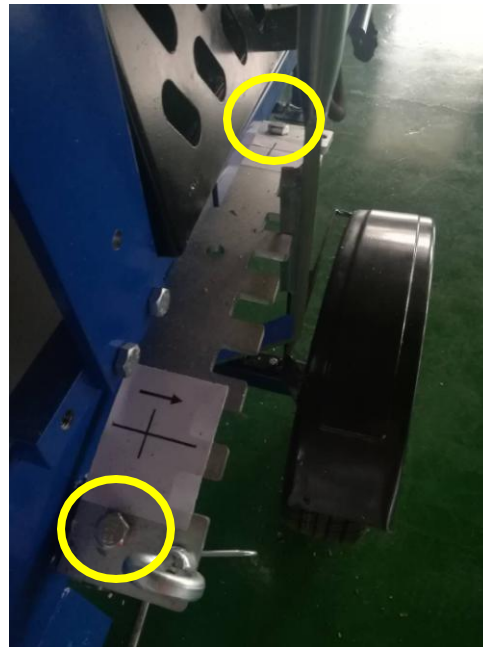

5.18. Install the 2/4 way splitter bottom support as shown below. The handle can also be installed at this point along with the 2/4 way splitter.

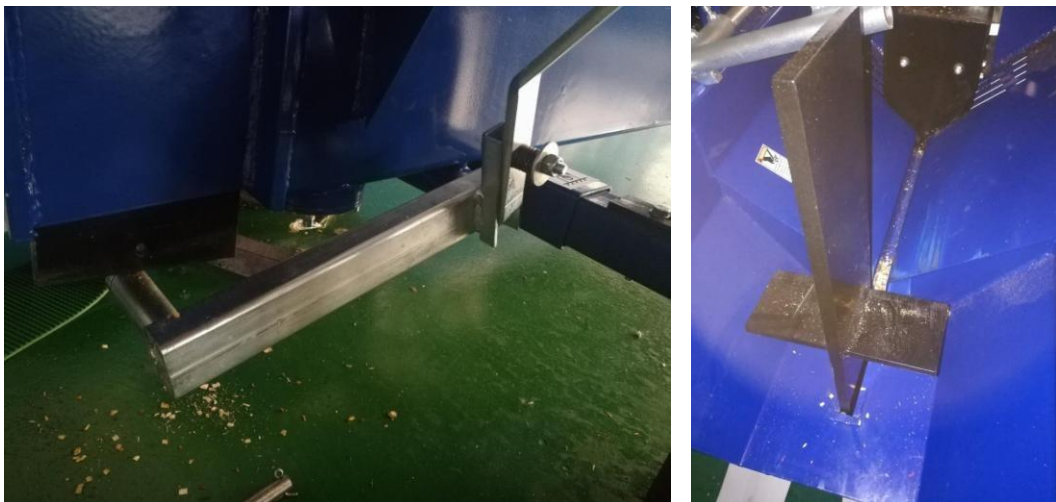

5.19. The chain can now be adjusted to ensure the tension is set correctly. Proper chain tension is achieved when the chain can be pulled away from the bar by hand 6.4mm-12.7mm. To tighten or loosen the chain, the two bolts can be loosened using a 13mm wrench. Next, the hexagon socket bolt can be turned clockwise to tighten or counter-clockwise to loosen the chain. The two 13mm bolts can be tightened again to hold the bar securely.



Picture after machine installation is completed



With the firewood processor now assembled, the conveyor system can be unpacked from the cardboard packaging and laid out, ready to be assembled and installed to the processor.

5.20. Assemble the gutters with the bolt from the inside out as shown.



5.21. Attach the upper drive roller to the top of the elevator



5.22. Connect the conveyor to the processing machine, lift it into place, align the mounting holes, and fix them with screws.

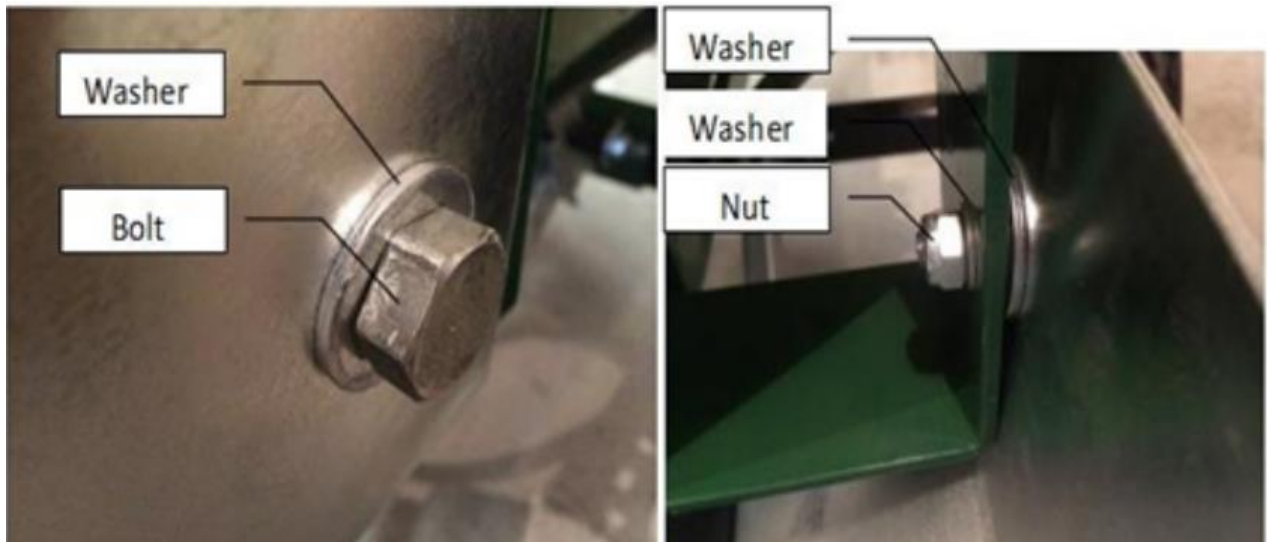
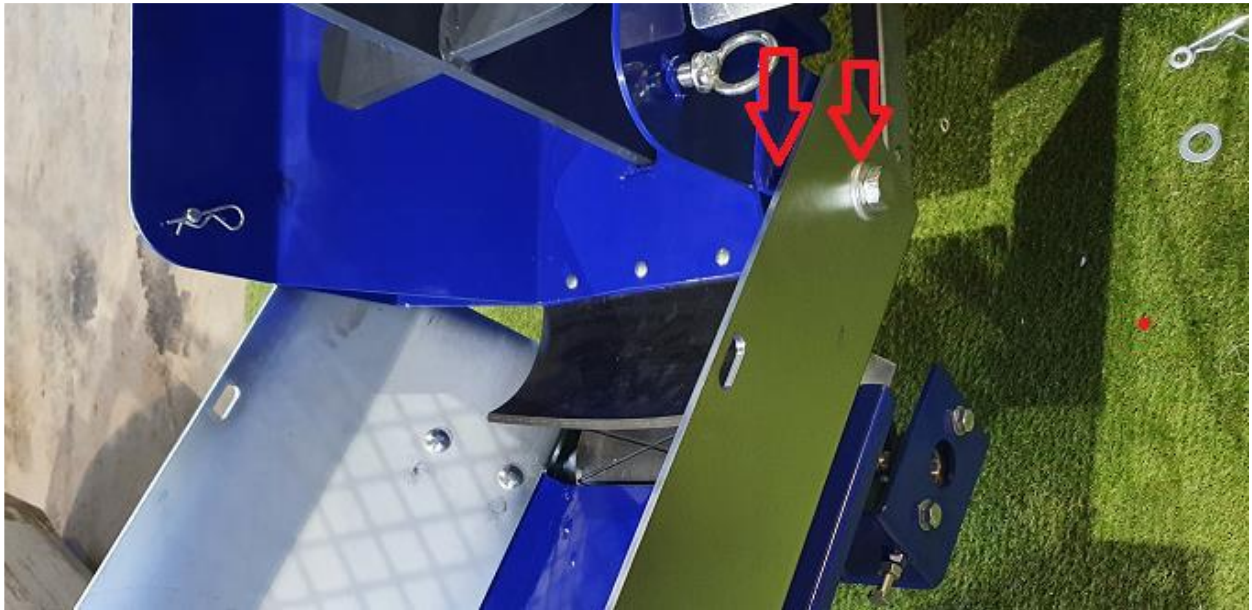

5.23. Insert the conveyor belt as follows with the bolts down and fasten it

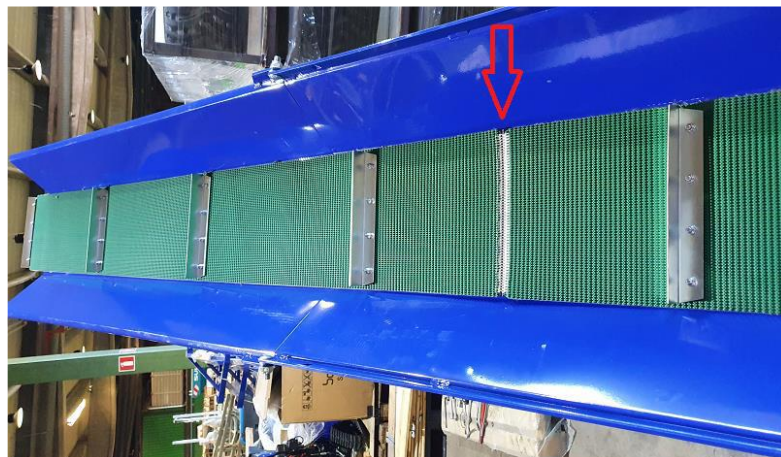

5.24. Install winch wing plate, cable wheels, and hooks, then install manual winches and cable connections

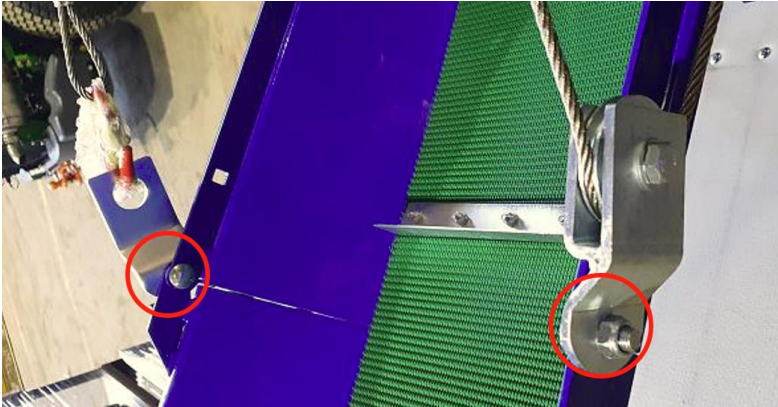

5.25. Lift the conveyor, install support feet and lock chains.



5.26. The conveyor belt can now be tightened by turning the “T” handle clockwise until the belt is taut.



6 Operation

6.1 Preparations

Place the machine on a flat and stable surface. Check all oil levels and fill up if necessary. Check that the machine does not have any defects. Remember to use proper protective equipment.

6.2 Operating

Adjusting the log length

The log length stop is adjusted with two screws. Unscrew these, move the allocation to the desired position and tighten the screws to adjust the log length.

Splitting the log

Place the log on the feed table and push it against the stop. Check that both protective cages are lowered and then cut the log.

7 Maintenance

7.1 Maintenance

Clean the machine and make sure that all saw dust is removed. Keep the machine indoors if possible. If the machine is stored outside, it must be covered with tarpaulin or cover.

Pay attention to the value of the oil filter pressure gauge during use. The oil must be cleaned or replaced if the value reaches to the red line. Please especially note that hydraulic oil must be distinguished between winter oil and summer oil.

7.2 Chainsaw Bar

Check before each use that there is no damage or similar to the chainsaw bar. Make sure to always work with a sharp chain, as this makes work much easier.

7.3 Adjusting the chain

Release the two bolts on the saw bar (see page 19) and adjust the tension screw. Tighten the screw to tighten the chain and vice versa. Then tighten the two bolts on the saw bar. You should be able to lift the chain about 6.4mm to 13mm from the saw bar. Remember not to tighten the chain too tight.

8 Wear parts

Name	Installing position	Qty	Type
Coupling (98.99.100)	Connecting engine and oil pump	1set	Transmission part
Hydraulic cylinder control line	Connecting 105.CEBA valve to 76.motor base welding part	1pc	Transmission part connector
Chain saw bar (81)	76 Motor base welding part	1pc	Sawing log
Saw chain (82)	76Motor base welding part	1pc	Sawing log
Conveyor belt (131)	conveyor	1pc	transporting log

9 Hydraulic drawings and components list

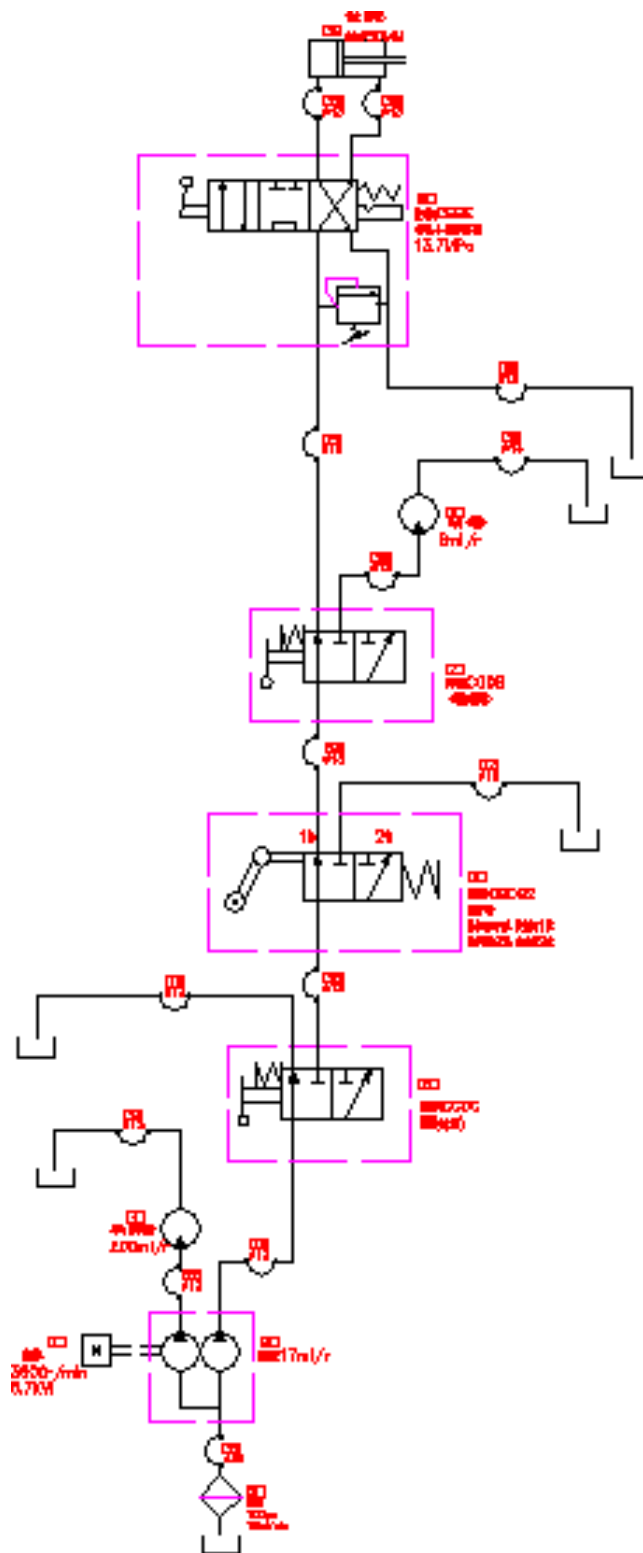

Hydraulic components list

No.	Name and specification	Quantity
1	Engine 3600r/min 6.7kw	1
2	Oil filter 100µm 100ml/min	1
3	Duplex pump 17ml/r	1
4	Motor 200ml/r	1
5	Reversing valve CGDG	1
6	Reversing valve CGDG2	1
7	Reversing valve CGDG	1
8	Motor 8ml/r	1
9	Reversing valve CEBE13.7MPa	1
10	Oil cylinder -inside diameter 80mm	1
11	Hydraulic pipe φ 25*500mm	1
12	Hydraulic pipe φ 13*2000mm	1
13	Hydraulic pipe φ 13*1000mm	1
14	Hydraulic pipe φ 13*700mm	1
15	Hydraulic pipe φ 13*600mm	1
16	Hydraulic pipe φ 13*1200mm	1
17	Hydraulic pipe φ 13*700mm	1
18	Hydraulic pipe φ 13*950mm	1
19	Hydraulic pipe φ 13*1100mm	1
20	Hydraulic pipe φ 13*1200mm	1
21	Hydraulic pipe φ 13*600mm	1
22	Hydraulic pipe φ 13*400mm	1
23	Hydraulic pipe φ 13*600mm	1
24	Hydraulic pipe φ 13*600mm	1

10 Attaching information

10.1 Free service

The warranty period for structural parts of this machine is two years, and for hydraulic accessories is one year.

10.2 Charge service

- Damage resulted from improper installing, operating, maintaining and forbidden items in the instructions.
- Damage caused by repair or modification by yourself without permission of this company.
- Damage caused by changing or adding other spare parts produced by other companies on this machine without permission
- Damage caused by the fire or natural disaster.

HYMA Skog & Trädgård

Hantverksgatan 15

314 34 Hyltebruk

info@hyma.se